

## Crane Scale



**SE-OCS-XZ1 series**

Single-side Display Type

Drawings:

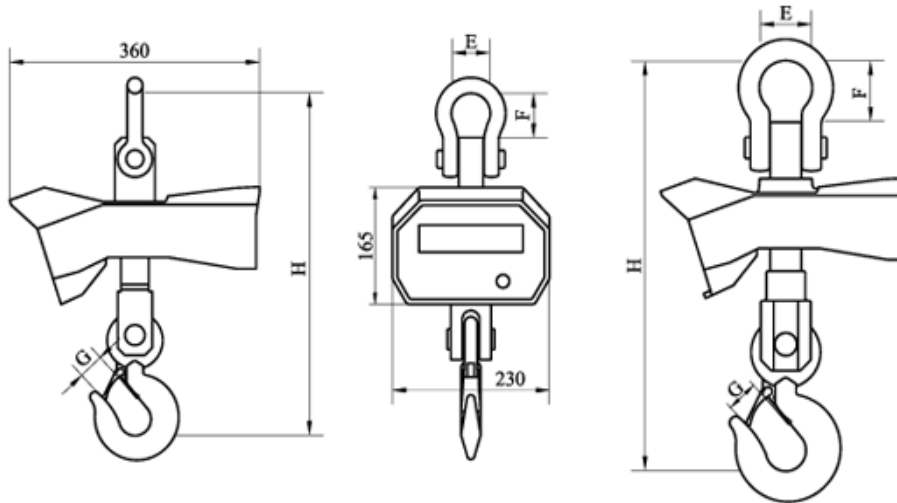

2t.3t.15t.20t

5t.10t

### Technical parameters and function character:

- High strength aluminum alloyed housing
- Super-bright LCD with backlight function or LED display (height:30mm)
- Three-dot linear calibration
- Revisable acceleration of gravity
- Automatic zero tracking
- Automatic battery voltage detection when turnon
- Automatic data storage when power-off
- Automatic standby and power-saving mode in 5mins without use
- Automatic shut-off in 1.5 hrs without use
- Transferable units of kg and lb
- Effective infrared remote control distance >10m
- Sealed and maintenance-free rechargeable 6V/10Ah battery
- Accuracy Class OIML III
- Taring Range 100% scale capacity
- Display Steady Time 5-10 seconds
- Ultimate Safety Factor 4
- Maximum Safety Overload 125% scale capacity
- CE certificate

### Specifications:

Model No.	Capacity(kg)	Division Value(kg)	Number	Size(mm)				N.W.(kg)	Note: *--optional, extended shackle size and weight are only for your reference.
				H	E	F	G		
SE-OCS-XZ1-0.5	500	0.2	2500	365	48	60	22	12	
SE-OCS-XZ1-1	1000	0.5	2000	420	56	65	22	15	
SE-OCS-XZ1-2	2000	1	2000	435	56	65	25	16	
SE-OCS-XZ1-3	3000	1	3000	460	56	65	32	20	
SE-OCS-XZ1-5	5000	2	2500	595	72	90	36	23	
				620*	85	115			
SE-OCS-XZ1-10	10000	5	2000	660	90	110	50	34	
				710*	110	160			
SE-OCS-XZ1-15	15000	5	3000	920	140	230	60	67	
SE-OCS-XZ1-20	20000	10	2000	980	140	230	70	75	