

## Crane Scale



### SE-OCS-XZH series

High-Temperature  
Protection Type

Drawings:

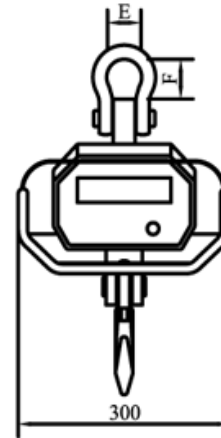
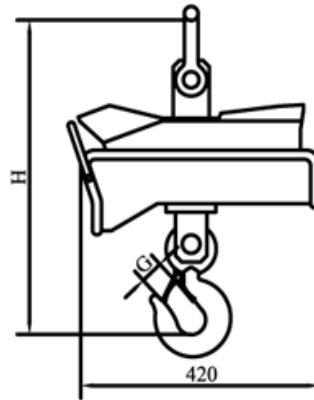

### Technical parameters and function character:

- High strength aluminum alloyed housing
- Special design for high temperature casting industry (<1600°C)
- Super-bright LED display (height:30mm)
- Revisable acceleration of gravity
- Three-dot linear calibration
- Automatic zero tracking
- Automatic battery voltage checking
- Automatic standby and power-saving mode in 5mins without use
- Automatic shut-off in 1.5 hours without use
- Automatic data saving when power-off
- Effective infrared remote control distance >10m
- Sealed and maintenance-free rechargeable 6V/10Ah battery
- Accuracy Class OIML III
- Tarring Range 100% scale capacity
- Display Steady Time 5-10 seconds
- Ultimate Safety Factor 5
- Maximum Safety Overload 125% scale capacity
- Minimum safety distance between the crane scale and the surface of hot steel liquid : 1000°C/1.5m, 1200°C/1.6m, 1400°C/1.8m, 1600°C/2.0m
- CE certificate

### Specifications:

Model No.	Capacity(kg)	Division Value(kg)	Number	Size(mm)				N.W.(kg)	
				H	E	F	G		
SE-OCS-XZH-1	1000	0.5	2000	465	56	65	25	26	Note: *--optional, extended shackle size and weight are only for your reference.
SE-OCS-XZH-2	2000	1	2000	490	56	65	32	30	
SE-OCS-XZH-3	3000	1	3000	570	72	90	36	36	
				595*	85	115			
SE-OCS-XZH-5	5000	2	2500	640	90	110	50	42	
				690*	110	160			
SE-OCS-XZH-10	10000	5	2000	920	140	230	60	77	
SE-OCS-XZH-15	15000	5	3000	980	140	230	70	85	